

# TM 11-5855-209-23

DEPARTMENT OF THE ARMY TECHNICAL MANUAL

---

## ORGANIZATIONAL AND DS MAINTENANCE MANUAL

### NIGHT VISION SIGHT

### MINIATURIZED AN/PVS-3

(NSN 5855-00-832-9341)

AND

### AN/PVS-3A (NSN 5855-00-156-4992)

This copy is a reprint which includes current  
pages from Changes 1 through 5.

---

HEADQUARTERS, DEPARTMENT OF THE ARMY

20 FEBRUARY 1968

CHANGE }  
No. 5 }

HEADQUARTERS  
DEPARTMENT OF THE ARMY  
WASHINGTON, DC, 2 January 1979

**Organizational and Direct Support Maintenance Manual  
Including Repair Parts and Special Tools Lists  
NIGHT VISION SIGHTS, MINIATURIZED  
AN/PVS-3 (NSN 5855-00-832-9341)  
AND  
AN/PVS-3A (NSN 5855-00-156-4992)**

TM 11-5855-209-23, 20 February 1968, is changed as follows:

1. The title of the manual is changed as shown above.
2. Remove and insert pages as indicated in page list below:  

<i>Remove</i>	<i>Insert</i>
Warning (inside front cover)	Warning (inside front cover)
3. File this change sheet in the front of the manual for reference purposes.

By Order of the Secretary of the Army:

BERNARD W. ROGERS  
*General, United States Army*  
*Chief of Staff*

Official:

J. C. PENNINGTON  
*Brigadier General, United States Army*  
*The Adjutant General*

Distribution:

*Active Army:*

USAINSCOM (2)	Ft Richardson (CERCOM) (2)	17-95
COE (1)	Army Dep (1) except	17-105
TSG (1)	LBAD (14)	17-107
USAARENBD (1)	SAAD (30)	29-16
DARCOM (1)	TOAD (14)	29-36
TRADOC (2)	SHAD (3)	29-134
OS Maj Comd (4)	USA Dep (1)	29-136
TECOM (2)	Sig Sec USA Dep (1)	29-137
USACC (4)	Units org under fol TOE:	57-42
MDW (1)	(1 cy each, UNOINDC)	29-207 (2)
Armies (2)	5-25	29-610 (2)
Corps (2)	5-127	
USAIB (2)	5-137	
USAIC (2)	5-146	
Svc Colleges (1)	5-155	
USASIGS (5)	5-215	
USAADS (10)	7-15	
USAFAS (5)	7-35	
USAARMS (20)	7-45	
USAIS (20)	7-55	
USAES (20)	7-102	
USAICS (3)	11-35	
MAAG (1)	11-36	
USARMIS (1)	11-37	
USAERDAA (1)	11-38	
USAERDAW (1)	11-39	
7th USA (10)	11-95	
8th USA (10)	11-117	
Fort Gillem (10)	11-215	
Fort Gordon (10)	11-216	
Fort Huachuca (10)	11-500 (AA-AC)	
Fort Carson (5)	17-35	
F't Monmouth (HISA) (26)	17-52	

*NG:* None

*USAR:* None

For explanation of abbreviations used, see AR 310-50.

## WARNING

RADIATION HAZARD



RADIOACTIVE MATERIAL  
THORIUM - 232

THE OPTICAL GLASS IN THE NIGHT VISION SIGHT MAY CONTAIN THORIUM AND PRESENT A POSSIBLE EYE HAZARD. A GREEN KNURLED RING, JUST FORWARD OF THE EYESHIELD INDICATES THAT THE NIGHT VISION SIGHT IS SAFE TO USE.

STD-RW-2

Image Intensifier      Th232      Less than 30%      5855-054-8490

Radiation Hazard Information: The following radiation hazard information must be read and understood by all personnel before operating or repairing Night Vision sights NA/PVS-3 and AN/PVS-3A. Hazardous radioactive materials are present in the above listed component of the MK-8200/UV.

The components are potentially hazardous when broken. See qualified medical personnel and the local Radiological Protection Officer (RPO) immediately if you are exposed to or cut by broken components. First aid instructions are contained in TB 43-0122, and AR 755-15.

NEVER place radioactive components in your pocket. Use extreme care NOT to break radioactive components while handling them.  
NEVER remove radioactive components from cartons until you are ready to use them.

If any of these components are broken, notify the local RPO immediately. The RPO will survey the immediate area for radiological contamination and will supervise the removal of broken components. The above listed radioactive components will not be repaired or disassembled.

Disposal of broken, unserviceable, or unwanted radioactive components will be accomplished in accordance with the instructions in AR 755-15.

ORGANIZATIONAL AND DS MAINTENANCE MANUAL  
NIGHT VISION SIGHT, MINIATURIZED AN/PVS-3

	Paragraph	Page
CHAPTER 1. INTRODUCTION		
Section I. General		
Scope .....	1-1	1-1
Indexes of publication .....	1-2	1-1
Reporting of equipment manual improvements .....	1-3	1-1
II. Functioning of Equipment		
Objective lens assembly .....	1-4	1-1
Image intensifier tube .....	1-5	1-1
Eyepiece assembly .....	1-6	1-2
CHAPTER 2. ORGANIZATIONAL MAINTENANCE		
Scope of organizational maintenance .....	2-1	2-1
Tools, materials, and test equipment .....	2-2	2-1
Organizational monthly preventive maintenance checks and services .....	2-3	2-1
Maintenance of carrying case .....	2-4	2-1
Removal and replacement of eyeshield .....	2-5	2-2
CHAPTER 3. DIRECT SUPPORT MAINTENANCE		
Section I. General		
Scope of direct support maintenance .....	3-1	3-1
Tools, materials, and test equipment .....	3-2	3-1
Operational testing .....	3-3	3-1
Power distribution .....	3-4	3-1
Continuity check .....	3-5	3-2
II. Troubleshooting		
Troubleshooting checks .....	3-6	3-2
Image blurred .....	3-7	3-2
Weak or no illumination of image intensifier tube .....	3-8	3-2
Mechanical troubles .....	3-9	3-2
III. Removal and Replacement		
Range focus ring nylon bearings .....	3-10	3-3
Battery retainer cover .....	3-11	3-3
Focusing tube stop screw .....	3-12	3-3
Power switch .....	3-13	3-3
Objective lens assembly .....	3-14	3-3
Eyepiece assembly .....	3-15	3-4
Image intensifier tube .....	3-16	3-4
Focusing tube .....	3-17	3-5
Main body .....	3-18	3-6
Range focus ring .....	3-19	3-6
APPENDIX A. REFERENCES .....		
		A-1
B. MAINTENANCE ALLOCATION .....		
		B-1

## CHAPTER 1

### INTRODUCTION

---

#### Section I. GENERAL

##### 1-1. Scope

a. This manual contains organizational and direct support (DS) maintenance instructions for Night Vision Sight AN/PVS-3 and AN/PVS-3A (night sights). It includes basic functioning of the night sight, troubleshooting, and removal and replacement procedures for parts available at the organizational and DS category of maintenance.

b. The maintenance allocation chart (MAC) appears in appendix B. The repair parts and special tools list appears in appendix C. Appendix C is current as of 13 October 1971.

c. Operating instructions are contained in TM 11-5855-209-10.

##### NOTE

For applicable forms and records, see paragraph 1-3, TM 11-5855-209-10.

##### 1-2. Indexes of Publications

a. *DA Pam 310-4*. Refer to the latest

issue of *DA Pam 310-4* to determine whether there are new editions, changes, or additional publications pertaining to the equipment.

b. *DA Pam 310-7*. Refer to *DA Pam 310-7* to determine whether there are modification work orders (MWO's) pertaining to the equipment.

##### 1-3. Reporting of Equipment Manual Improvements

Reporting of errors, omissions, and recommendations for improving this publication by the individual user is encouraged. Reports should be submitted on DA Form 2028 (Recommended Changes to Publications) and forwarded direct to Commanding General, U.S. Army Electronics Command, ATTN: AMSEL-MA-A, Fort Monmouth, N. J., 07703.

#### Section II. FUNCTIONING OF EQUIPMENT

##### 1-4. Objective Lens Assembly (fig. 3-2)

The objective lens assembly (2) used the available light of the night sky to focus an image of the scene being viewed on the front screen of the image intensifier tube (14). Under nighttime illumination conditions, this image may be very dim and not visible to the naked eye. Focusing of the image is accomplished by varying the distance of the image intensifier tube (14) from the objective lens assembly.

##### 1-5. Image Intensifier Tube (fig. 3-2)

The image intensifier tube (14) receives the dim image from the objective lens assembly (2), amplifies it, and displays the image on the rear screen of the tube. The brightness of the image is amplified to such a degree it can be seen with the naked eye. Power for operation of the image intensifier tube is supplied by the 2.8-volt battery tray (10).

**1-6. Eyepiece Assembly**  
(fig. 3-2)

The eyepiece assembly (18) magnifies the image displayed on the rear screen of the image intensifier tube (14). Focusing of the image is accomplished by varying the distance of the eyepiece assembly from the rear screen of the image intensifier tube.

**CHAPTER 2**

**ORGANIZATIONAL MAINTENANCE**

**2-1. Scope of Organizational Maintenance**

The maintenance duties assigned to the organizational maintenance personnel are listed below together with reference to the paragraphs covering the specific maintenance duty. These duties are performed in addition to those given in the operator's daily preventive maintenance checks and services chart (TM 11-5855-209-10).

*a.* Monthly preventive maintenance checks and services (para 2-3).

*b.* Removal and replacement of eye shield (para 2-5).

*c.* Installation and removal of the bore-sight mount (para 2-6 and 2-7).

*d.* Installation and removal of the M-14 Adapter Bracket (para 2-8).

*e.* Installation and removal of the M-16 Adapter Bracket (para 2-9).

**2-2. Tools, Materials, and Test Equipment**

A small screwdriver is the only tool required. A lint free cloth (FSN 8305-170-5062) is required for general cleaning. No test equipment is required for organizational maintenance of the night sight.

**2-3. Organizational Monthly Preventive Maintenance Checks and Services**

<i>Sequence No.</i>	<i>Item to be inspected</i>	<i>Procedure</i>	<i>Remarks or reference</i>
1 <sup>a</sup>	Eye-piece . . . . .	<i>a.</i> Remove eyeshield . . . . . <i>b.</i> Clean eyepiece lens . . . . .	<i>a.</i> Para 2-5. <i>b.</i> TM 11-5855-209-10. <i>Note.</i> Refer to TM 11-5855-209-10.
2	Cover assembly cap . . . . .	<i>a.</i> Check for proper fit . . . . . <i>b.</i> Check for cracks . . . . . <i>c.</i> Clean cap lens . . . . .	<i>a.</i> Replace. <i>b.</i> Replace. <i>c.</i> TM 11-5855-209-10.
3	Eyeshield . . . . .	Check for tears, holes, or signs of deterioration.	Para 2-5.
4 <sup>b</sup>	Carrying Case . . . . .	<i>a.</i> Examine for evidence of rotting or weakening of fabric by stretching or pulling. <i>b.</i> Check for mildew, oil or grease.	<i>a.</i> Replace.  <i>b.</i> Para 2-4.
5	Technical manual . . . . .	Check for torn or missing pages and general condition.	Replace.

<sup>a</sup>To be performed daily if required.

<sup>b</sup>To be performed daily or weekly (as required) in tropical areas.

**24. Maintenance of Carrying Case**

*a. Mildew.* To prevent the formation of mildew, air the carrying case for several hours. Remove mildew by scrubbing with a dry, stiff brush. If water is necessary

to remove dirt, do not use it until all mildew has been removed.

*b. Oil and Grease.* Oil and grease can be removed from the carrying case by scrubbing with soap and warm water. Rinse



well in clear water and allow the carrying case to dry thoroughly before installing the night sight.

**2-5. Removal and Replacement of Eyeshield**

(fig. 3-3)

Replace the eyeshield when it is torn, cracked, or otherwise unserviceable.

*a. Removal.* Grasp the eyeshield (8) and turn it counterclockwise.

*b. Replacement.* Replace the eyeshield (8) on the retaining ring (5) and tighten clockwise.

**NOTE**

Remove four screws (6) to remove the retaining ring (5).

**2-6. Installation and Removal of Boresight Mount (AN/PVS-3A Only)**

(fig. 3-2)

*a. Installation.* Install the two screws (27) and tighten.

*b. Removal.* Unscrew the two screws (27) that attach the boresight mount to the main body (4).

**2-7. Installation and Removal of Boresight Mount (AN/PVS-3 Only)**

(fig. 3-3)

*a. Installation.* Install the two screws (11); install strap (12) around boresight (1) with relief toward screw (2). Place spring (14) in position against coupler ring (3); and thread screw (13) through strap (12), spring (14), boresight mount (15), and tighten.

*b. Removal.* Unscrew the two screws (11) from objective cell flange. Unscrew screw (13) from strap (12), spring (14), boresight mount (15), and remove strap (12) from around boresight. Retain spring (14) for reassembly.

**2-8. Installation and Removal of M-14 Adapter Bracket**

(fig. 2-1)

*a. Installation.*

(1) Position the adapter bracket on

the receiver assembly.

(2) Position the washer and screw and tighten down the screw by turning it clockwise.

*b. Removal*

(1) Remove the screw and washer by turning the screw counterclockwise.

(2) Lift the adapter bracket from the receiver assembly.

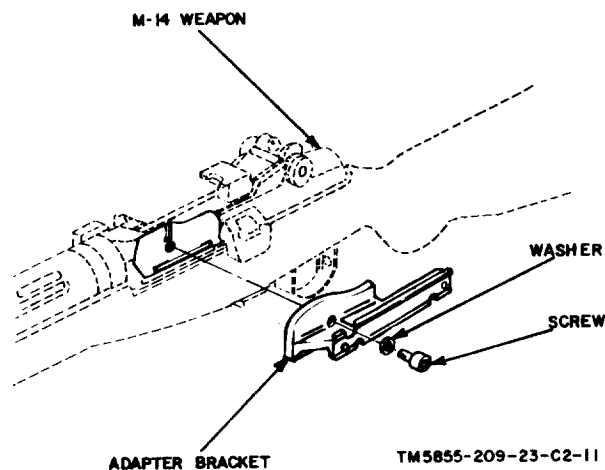

Figure 2-1. Adapter bracket M-14.

**2-9. Installation and Removal of M-16 Adapter Bracket**

(fig. 2-2)

*a. Installation.*

(1) Place the adapter bracket against the weapon handle and receiver and push inward and downward until the mounting ears are under and around the weapon handle.

(2) Position the adapter bracket flat against the top of the receiver and all the way forward.

(3) Tighten the wingnut by turning it clockwise.

*b. Removal.*

(1) Loosen the wingnut by turning it counterclockwise.

(2) Grasp the adapter bracket and remove in an upward and outward direction until the mounting ears clear the weapon handle.

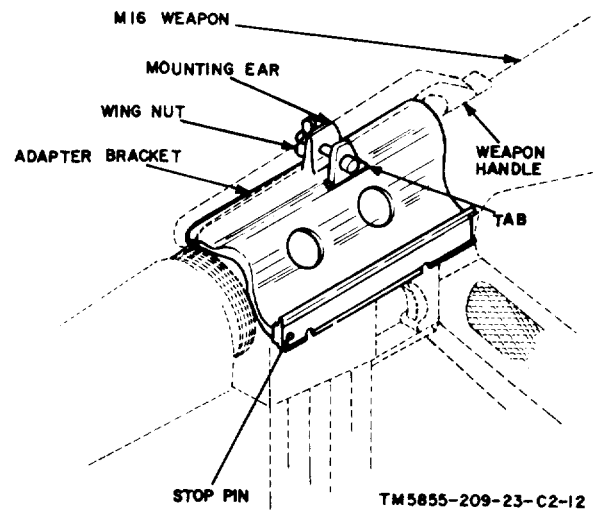

Figure 2-2. Adapter bracket M-16.

## CHAPTER 3

### DIRECT SUPPORT MAINTENANCE

---

#### Section I. General

#### 3-1. Scope of Direct Support Maintenance

The maintenance duties assigned to direct support maintenance personnel are listed below, together with reference paragraphs covering the specific maintenance duty. These duties are performed in addition to those assigned to the operator (TM 11-5855-209-10) and organizational maintenance personnel (para 2-1).

- a. Troubleshooting (paras 3-6 and 3-9).
- b. Removal and replacement of components (paras 3-10 through 3-20).
- c. Testing (para 3-3).

#### 3-2. Tools, Materials, and Test Equipment

a. *Tools.* The tools required for direct support maintenance are contained in Toolkit, Electronic Equipment TK-100/G (app. B).

b. *Materials.*

(1) Silicone compound, Dow Corning, DC-4 (MIL-G-8660, FSN) or equivalent, is required for lubricating o-rings and threads.

(2) Acetone (FED STD Q-A-51d) or equivalent is required for cleaning the parts of the boresight mount.

(3) Molybdenum disulfate (MIL-G-21164) is required for lubrication of the boresight mount.

c. *Test Equipment.* A multimeter (Multimeter TS-352B/U or equivalent) is required for direct support maintenance (app. B).

#### 3-3. Operational Testing

An operational test should be performed whenever the image intensifier tube, ob-

jective lens assembly, eyepiece assembly, main body components, or electrical components have been replaced or repaired. Refer to the operator's daily preventive maintenance checks and services chart in TM 11-5855-209-10.

#### 3-4. Power Distribution

(fig. 3-1)

The path for current flow through the night sight is given below.

- a. From the image intensifier tube power pin to the power contact spring.
- b. From the power contact spring to the printed circuit board.
- c. From the printed circuit board to the negative side of the battery tray.
- d. From the positive side of the battery in the battery tray to the battery contact spring.
- e. From the battery contact spring to the negative side of the battery in the battery tray.
- f. From the positive side of the battery in the battery tray to the printed circuit board.
- g. From the printed circuit board to power switch terminal A.
- h. From power switch terminal B to the printed circuit board.
- i. From the printed circuit board to the ground contact spring.
- j. From the ground contact spring to the focusing tube.
- k. From the focusing tube ground contact spring to the ground pin.

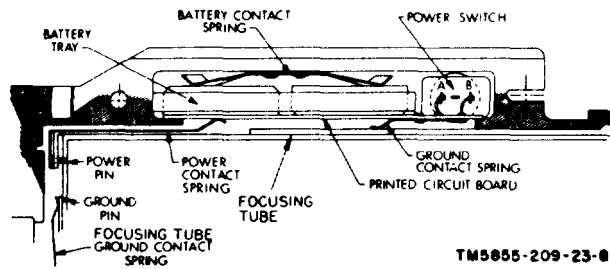

Figure 3-1. Night sight, location of electrical parts.

### 3-5 Continuity Check (fig. 3-1)

a. The wiring, printed circuit board, power switch, and electrical contact springs may be checked for electrical continuity with a multimeter as indicated below. Insure that a fresh battery tray is installed.

- (1) Place the power switch in the off position (toward the objective lens end of the night sight).
- (2) Remove the eyepiece assembly (para 3-15).
- (3) Remove the image intensifier tube (para 3-16).

- (4) Set the multimeter range selector to measure 3 volts direct current (dc).
- (5) Connect the multimeter negative lead to the ground contact spring.
- (6) Place the power switch in the on position (toward eyepiece assembly end of the night sight).
- (7) Place the multimeter positive test probe onto the power contact spring inside the focusing tube (13, fig. 3-2).
- (8) The multimeter should indicate between 2.6 and 2.8 volts dc.
- (9) Place the power switch in the off position (toward objective lens end of the night sight). The multimeter should indicate 0.

b. If the electrical continuity check in a above reveals an open circuit, the power switch must be removed (para 3-13) and the individual wires and power switch must be checked for continuity. If the continuity check of the power switch and wires is satisfactory, remove the focusing tube (para 3-17) and check for defective electrical contact springs.

## Section II. TROUBLESHOOTING

### 3-6. Troubleshooting Checks

This section provides information for diagnosing and correcting unsatisfactory operation or failure of the night sight or any of its components. Each trouble symptom (para 3-7 and 3-8) contains a list of probable causes with the corrective measure. The mechanical troubles with corrective measures are contained in paragraph 3-9.

### 3-7. Image Blurred

Probable cause	Corrective measure
Defective image intensifier tube.	Replace image intensifier tube (para 3-16).
Damaged or defective objective lens assembly.	Replace objective lens assembly (para 3-14).
Damaged or defective eyepiece assembly.	Replace eyepiece assembly (para 3-15).

3-2 Change 2

### 3-8. Weak or No Illumination of Image Intensifier Tube

Probable cause	Corrective measure
Defective image intensifier tube.	Replace image intensifier tube (para 3-16).
Defective power switch.	Replace power switch (para 3-13).
Defective focusing tube electrical contact spring.	Replace focusing tube (para 3-17).

### 3-9. Mechanical Troubles

Probable cause	Corrective measure
Range focus ring will not rotate.	Para 3-19.
Range focus ring, when turned counterclockwise, slips out of threads.	Para 3-12.
Boresight mount will not adjust properly in azimuth or elevation.	Para 3-20.

### Section III. REMOVAL AND REPLACEMENT

#### CAUTION

Be sure that the power switch is in the off position (toward the objective lens end of the night sight) before removing or replacing any components of the night sight.

#### 3-10. (Deleted.)

#### 3-11. Battery Retainer Cover

(fig. 3-2)

Replace the battery retainer cover when bent or when attaching thumbscrews are damaged or missing.

*a. Removal.* Unscrew and remove the battery cover hinge pin (7) from the battery housing.

#### CAUTION

Seal the battery cover hinge pin (7) with Loctite sealant or equivalent.

*b. Replacement.* Install a new battery retainer cover and insert a new battery cover hinge pin.

#### 3-12. Focusing Tube Stop Screw

(fig. 3-2)

##### *a. Removal.*

(1) Rotate the range focus ring (16) in a clockwise direction until the stop screw (8) is fully exposed.

(2) Unscrew the stop screw.

*b. Replacement.* Install a new stop screw and tighten only enough to seal O-ring against the main body.

#### CAUTION

Do not over torque screw.

#### NOTE

When removing the stop screw, make sure that the attached O-ring is also removed. When installing a new stop screw, make sure that the O-ring is attached.

#### 3-13. Power Switch

(fig. 3-2)

##### *a. Removal.*

(1) Open the battery retainer cover (9) and remove the battery tray (10).

(2) Use a small tip (pencil type) soldering iron and unsolder the wires connected to the power switch (11) terminals.

(3) Use a recessed socket wrench and remove the nut (6) from the power switch.

##### *b. Replacement.*

(1) Install the power switch (11) into the battery housing, thread the nut (6) to the power switch, and tighten.

(2) Solder the wires to the power switch (11) terminals.

(3) Remove all loose residue solder from the inside of the battery housing.

#### 3-14. Objective Lens Assembly

(fig. 3-2)

##### *a. Removal.*

(1) Unscrew six screws (5) from the main body (4).

(2) Remove the objective lens assembly (2) from the main body.

(3) Remove the O-ring (3) from the main body (4). Discard the O-ring.

##### *b. Inspection.*

(1) Inspect the optical surfaces for marks, cracks, or chips.

(2) Visually inspect the interior of the assembly for damage, condensation mildew, or fungus.

*c. Repair.* Replace the objective lens assembly with a new assembly if inspection reveals any damage, interior condensation, mildew, or fungus.

*d. Testing.* The only method of testing for a defective objective lens assembly is by substitution of a known good objective lens assembly.

*e. Replacement.* Before replacing the objective lens assembly, insure that all optical surfaces and mating metal surfaces are clean and dry.

(1) Install a new O-ring (3) on the main body (4).

(2) Align the slot on the objective lens assembly with the slot on the main body.

(3) Install the six screws (5) and tighten sequentially as shown in figure 3-1.1.

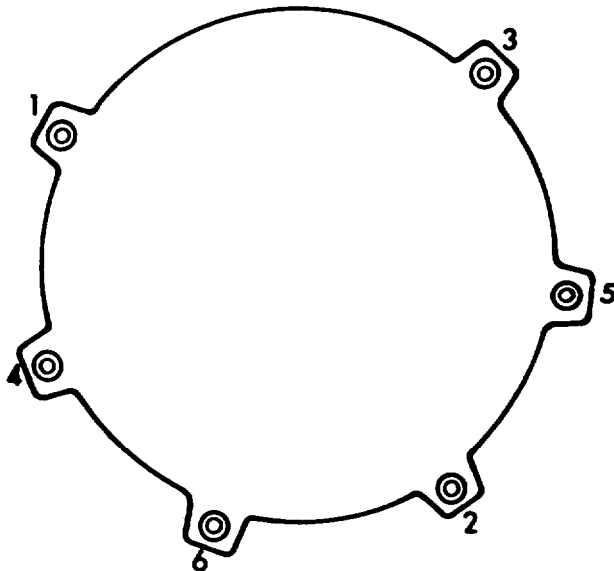

TM5855-209-23-CI-10

Figure 3-1.1. Screw Tightening Sequence.

### 3-15. Eyepiece Assembly (fig. 3-2)

#### CAUTION

**When removing the eyepiece assembly from the focusing tube, hold the eyepiece end up to prevent the image intensifier tube from sliding out.**

#### *a. Removal.*

(1) Grasp the eyepiece assembly (18) firmly by the focus ring and turn counter-

clockwise to unscrew the eyepiece assembly from the focusing tube (13).

(2) Remove the O-ring (17) from the eyepiece assembly.

#### *b. Inspection.*

(1) Inspect the exterior of the eyepiece assembly for mechanical damage.

(2) Inspect the threads for burrs or other damage.

(3) Inspect the optical surfaces for mars, cracks, or chips.

(4) Inspect the convolutions that mate with the image intensifier tube for damage.

(5) Visually inspect the interior of the assembly for damage, condensation, mildew, or fungus.

#### *c. Repair.*

(1) Remove burrs from the threads with a small file or emery cloth.

(2) Replace the eyepiece assembly with a new eyepiece assembly if inspection reveals any damage, interior condensation, mildew, or fungus.

*d. Testing.* The only method of testing a defective eyepiece assembly is by substitution of a known good eyepiece assembly.

*e. Replacement.* Before replacing the eyepiece assembly, insure that all optical surfaces are clean and dry. Clean the convolutions with lens tissue, wet with alcohol.

(1) Lubricate a new O-ring (17) with silicone compound and install on the eyepiece assembly (19).

(2) Thread the eyepiece assembly (18) into the focusing tube (13) in a clockwise direction until a snug fit is obtained. Make certain the focus ring is at its maximum clockwise stop position.

(3) Locate small hole on the eyepiece focus ring. While viewing through the hole, slowly turn the eyepiece focus ring counter-clockwise until the reference mark on the eyepiece body is in view through the hole on the focus ring. After removing all play between the eyepiece assembly and the focusing tube, back off the eyepiece assembly  $\frac{1}{4}$  turn.

(4) While holding the eyepiece body and focus ring firmly aligned, position the diopter indicator (wire pointer located under the fo-

cus ring) to indicate; diopter on the eyepiece body.

### 3-16. Image Intensifier Tube

(fig. 3-2)

#### WARNING

The image intensifier tube phosphor screens contain toxic material. If an image intensifier tube becomes broken, be extremely careful to prevent inhalation of the phosphor material. Do not allow it to come in contact with the mouth or open skin wounds.

*a. Removal.* Remove the eyepiece assembly (para 3-15).

#### CAUTION

The image intensifier tube may retain a static high-voltage charge. Do not touch metal components of the tube until discharged (3) below.

(1) Remove the image intensifier tube (14) from the main body (4).

(2) Remove battery tray (10).

#### NOTE

To remove the image intensifier tube, a gentle tap on the night sight while it is held at a slight angle (eyepiece end down) may be necessary. Keep the free hand over the open end of the main body (4) to prevent the image intensifier tube from falling.

(3) The image intensifier tube will discharge itself in a normally lighted area (roomlight, etc). Discharge may be verified by shorting across metal components of the image intensifier tube.

(4) Remove the image tube washer (15) from the image intensifier tube.

*b. Testing.* The only method of testing for a defective image intensifier tube is by substitution of a known good image intensifier tube.

*c. Replacement.* Before replacing the image intensifier tube, insure that the glass faces, ground pin, and power pin are clean.

(1) Note the position of the power pin

and ground pin on the image intensifier tube (14).

(2) Look at the inside end of the focusing tube (13) and note the position of the power and ground contact springs.

(3) Visually align the image tube contact pins with the focusing tube contact springs. Carefully insert the image intensifier tube into the focusing tube.

(4) Rotate the image intensifier tube slightly in either direction locate the image intensifier tube power and ground pins with the mating contact springs of the focusing tube.

(5) Install image tube washer (15) into the focusing tube.

(6) Thread the eyepiece assembly (18) into the focusing tube (13) in a clockwise direction.

(7) Replace battery tray (10).

### 3-17. Focusing Tube

(fig. 3-2)

*a. Removal.*

(1) Remove the image intensifier tube (14) (para 3-16).

(2) Remove the range focus ring set-screws (24).

(3) Remove the focusing tube stop screw (8) (para 3-12).

(4) Rotate the range focus ring clockwise to disassemble the focusing tube (13) from the main body (4). Pull focusing tube (13) gently from the main body.

#### CAUTION

Do not rotate focusing tube in main body when stop screw is removed. Power contact spring (fig. 3-1) may snag in main body (4). Forcing or rapidly extracting focus tube from main body may bend or break off power contact spring.

(5) Remove the range focus ring (16) from the main body (4).

*b. Inspection.*

(1) Inspect the threads for burrs or damaged threads.

(2) Inspect the power and ground contact springs for damage or corrosion.

*c. Repair.*

(1) Remove burrs from the threads with a small file or emery cloth. Clean the contact springs.

(2) Replace the focusing tube when inspection reveals damage, which renders the focusing tube unserviceable.

*d. Replacement.* Before replacing the focusing tube (13) and range focus ring (16), make sure that all threads are clean.

(1) Lubricate the threads on the main body (4), focusing tube (13), and range focus ring (16) with silicone compound.

(2) Place the range focus ring (16) on the main body (4). Do not start threads.

**NOTE**

The zero diopter mark on the focusing tube must be aligned with the focusing tube stop screw hole when performing (3) and (4) below.

(3) Gently insert the focusing tube (13) through range focus ring (16) and into the main body (4).

(4) Turn the range focus ring (16) clockwise until the range focus ring reaches the stop position.

(5) Install the focusing tube stop screw (8) (para 3-12).

**3-18. Main Body**  
(fig. 3-2)

*a. Removal.*

(1) Remove the objective lens assembly (para 3-14).

(2) Remove the focusing tube (para 3-17).

*b. Repair.*

(1) Remove burrs from the threads with small file or emery cloth.

(2) Replace the main body with a new main body if inspection reveals any dents, cracks, or other damage which renders the main body unserviceable.

*c. Replacement.*

(1) Install the objective lens assembly (para 3-14).

(2) Install the focusing tube (para 3-17d).

**3-19. Range Focus Ring**

Remove, inspect, repair, and replace range focus ring in accordance with paragraph 3-17.

**3-20. Boresight Mount, AN/PVS-3 and AN/PVS-3A**

(figs. 3-2, 3-3, and 3-4)

*a. Removal, AN/PVS-3 (fig. 3-3).* Remove screw (13) from boresight mount (15) and remove strap (12) and spring (14). Retain these components for reassembly.

*b. Removal, AN/PVS-3A (fig. 3-2).* Loosen the two captive screws (27) and the bore sight mount (25) will separate from night sight.

*c. Disassembly (fig. 3-4).*

(1) Place a screwdriver in the slot in pin (1) and relax the tension on pin (2).

(2) Remove pin (2), release and remove pin (1).

(3) Remove retaining ring (3) and lift the crossbar (4) from the boresight frame (5).

**NOTE**

Crossbar on the boresight mount for AN/PVS-3 is shown in figure 3-3. The crossbar illustrated in figures 3-2 and 3-4 is the one used with the AN/PVS-3A. Except for this difference, the boresight mounts are identical.

(4) Remove the spiral spring (6) from the crossbar (4) and remove captive screws (7) and (8). The flat spring (9) may be pulled out after removal of screw (8).

(5) Remove self-locking screw (10) and unscrew pin (11) from the shaft of knob (12).

(6) Remove knob (12), ball bearings (13 and 14), and compression spring (15) from the boresight frame (5).



(7) Remove retaining ring (16) and thrust washer (17) from the shaft of knob (18).

(8) Remove knob (18) from boresight frame (5) and post (19) by turning knob counterclockwise. The post (19), compression spring (20), and ball bearing (25) are now removable.

(9) Remove pin (21) from knob (22) and locking screw (23).

(10) Remove locking screw (23), knob (22), and washer (24) from boresight frame (5) by turning counterclockwise.

*d. Cleaning and Lubrication.*

(1) *Cleaning.* Clean both inside and outside surfaces, threads, grooves, and flanges of the boresight frame (5) and crossbar (4). Use a fine brass wire brush to remove dirt imbedded in grooves and flanges. Clean wipe components with a clean, lint free cloth saturated in acetone. Make certain that all parts are free of oil, grease, and other foreign matter.

(2) *Lubrication.* At assembly, lubricate the following items with molybdenum disulfide.

(a) Knob (12) shaft.

(b) Knob (18) shaft.

(c) Compression spring (15).

(d) Compression spring (20).

*e. Inspection.*

(1) Visually inspect all mechanical parts to be certain that they are free of oil, dust, or other foreign matter.

(2) Inspect all threads on metal parts for burrs or damaged threads.

(3) Inspect all metal parts for cracks or dents.

*f. Repair.* Remove all burrs from

threaded parts with a small file or emery cloth. Unrepairable items must be replaced.

*g. Assembly.*

(1) Place the knob (22) and washer (24) on the locking screw (23). Align the holes in the knob with the hole in the locking screw and insert pin (21).

(2) Insert the locking screw (23) into the boresight frame (5) and tighten securely.

(3) Insert post (19), compression spring (20), and ball bearing (25) into the boresight frame (5).

(4) Insert knob (18) through the boresight frame (5) and post (19) and install thrust washer (17) and retaining ring (16) to the shaft of the knob.

(5) Install compression spring (15), ball bearings (13 and 14), and knob (12) into the boresight frame (5).

(6) Install pin (11) onto the shaft of knob (12) and install self-locking screw (10) and tighten the screw securely.

(7) Install the flat spring (9), captive screws (7 and 8), and spiral spring (6) into the crossbar (4).

(8) Position the crossbar (4) onto the boresight frame (5). Align the hole on the crossbar to fit over post (19) and install retaining ring (3).

(9) Install pin (1) into the boresight frame (5), aligning the groove in the pin with the inside end of the spiral spring (6).

(10) Using a torque wrench with a screwdriver attachment, insert the screwdriver tip into pin (1) and tighten to a torque of 90 ( $\pm 10$ ) inch-pound. Align the pins slot with the holes in the boresight frame (5) and insert pin (2).

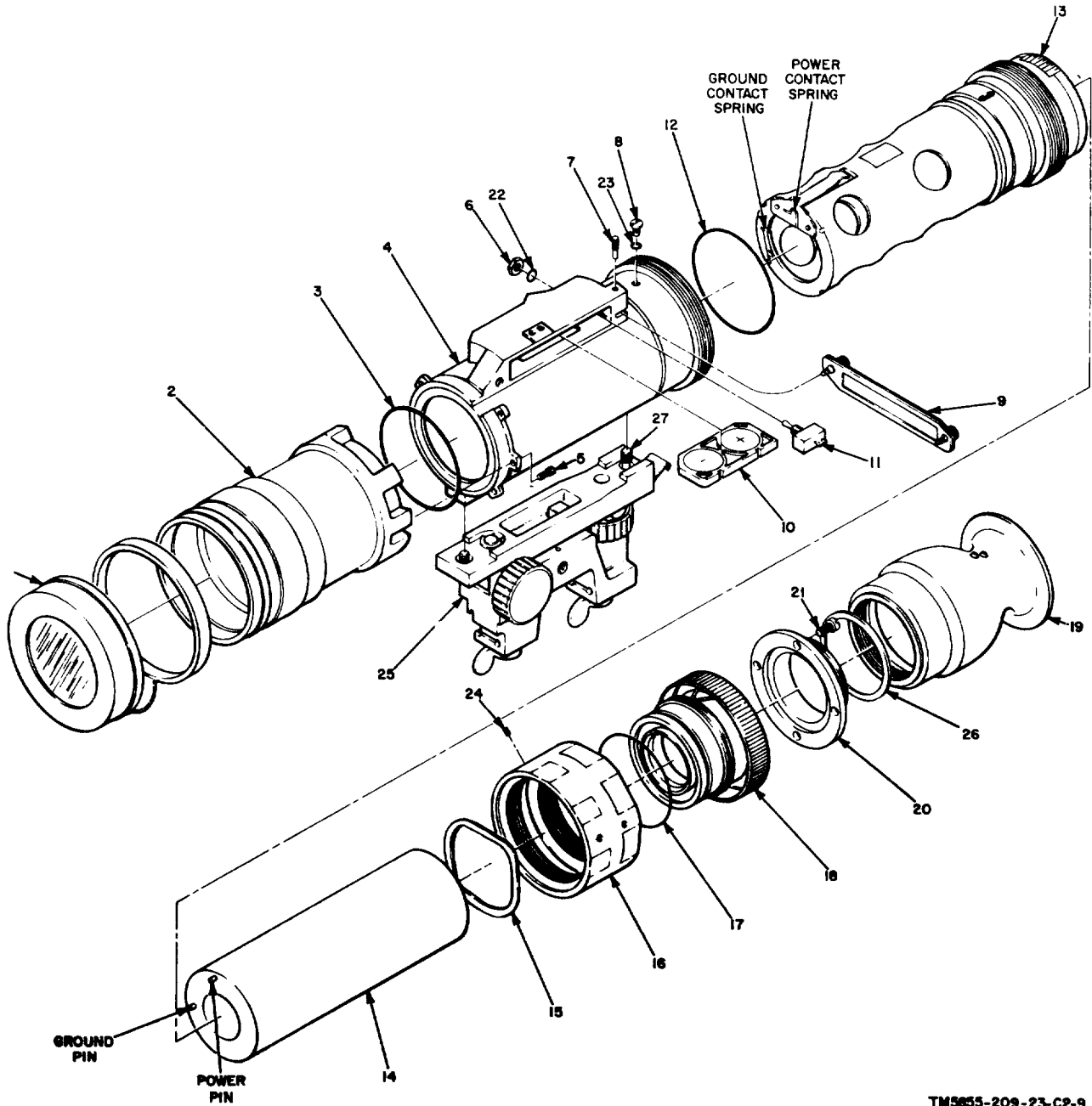

TM5855-209-23-C2-9

- |   |   |
|---|---|
| <ul style="list-style-type: none"> <li>1 Cover assembly, cap 1A1MP1</li> <li>2 Objective lens assembly 1A1</li> <li>3 O-ring 1MP2</li> <li>4 Main body 1A2</li> <li>5 Screw 1MP3-8</li> <li>6 Nut A2A148</li> <li>7 Hinge pin 1A2A1H4</li> <li>8 Focusing tube stop screw 1A2H1</li> <li>9 Battery retainer cover 1A241A2</li> <li>10 Battery tray A1E1</li> <li>11 Power switch A2A1S1</li> <li>12 O-ring 1A2MP2</li> <li>13 Focusing tube 1A2A2</li> <li>14 Image intensifier tube 1A2A2</li> </ul> | <ul style="list-style-type: none"> <li>15 Image tube washer 1MP4</li> <li>16 Range focus ring 1A2MP1</li> <li>17 O-ring 1MP1</li> <li>18 Eyepiece assembly 1A3</li> <li>19 Eyeshield 1A3A1A1</li> <li>20 Retaining ring 1A3A1MP1</li> <li>21 Screw 1A3H3</li> <li>22 Washer 1A2A1H7</li> <li>23 O-ring A2A1H7</li> <li>24 Setscrew 1A242-5</li> <li>25 Boresight mount 1A4</li> <li>26 Eyepiece spacer 1A3A1MP2</li> <li>27 Screw, captive 1A4H6</li> </ul> |
|---|---|

Figure 3-2. Night sight, exploded view (AN/PVS-3A).

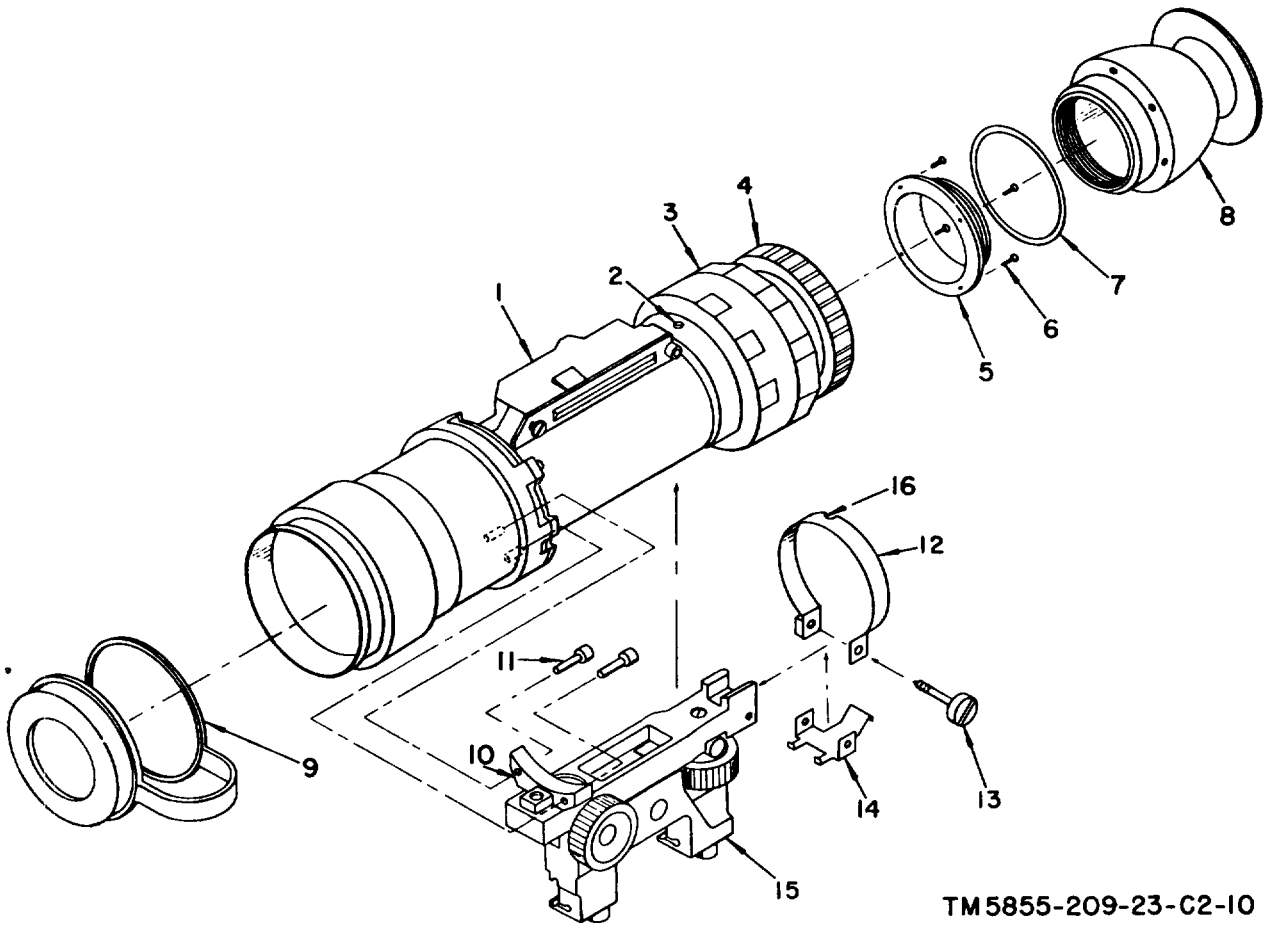

TM 5855-209-23-C2-10

- 1 Main body 1A2
- 1 Focusing tube stop screw 1A2H1
- 3 Focusing tube 1A2A2
- 4 Range focus ring 1A2MP1
- 5 Retaining ring 1A3A1MP1
- 6 Screw 1A3H3
- 7 Eyepiece spacer 1A3A1MP2
- 8 Eyeshield 1A3A1A1
- 9 Cover assembly cap 1A1MP1
- 10 Adapter bracket
- 11 Screw 1MP3-8
- 12 Strap
- 13 Screw
- 14 Spring, flat MP4
- 15 Boresight mount 1A4

Figure 3-3. Night sight, exploded view (AN/PVS-3).

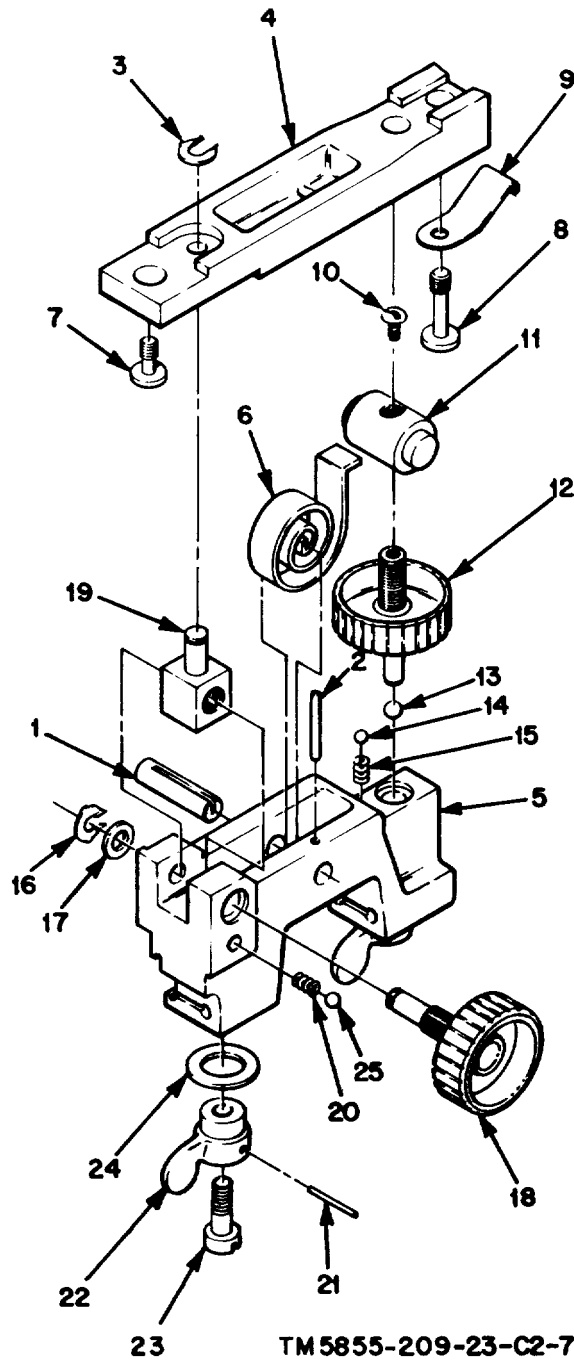

- |                            |                              |
|----------------------------|------------------------------|
| 1 Pin (MP1)                | 14 Ball bearing (MP9)        |
| 2 Pin (H1)                 | 15 Compression spring (MP10) |
| 3 Retaining ring (H2)      | 16 Retaining ring (H6)       |
| 4 Crossbar (MP3)           | 17 Thrust washer (H7)        |
| 5 Boresight frame (MP7)    | 18 Knob (MP11)               |
| 6 Sprial spring (MP2)      | 19 Post (MP12)               |
| 7 Captive screw (H3)       | 20 Compression spring (MP14) |
| 8 Captive screw (H4)       | 21 Pin (H8)                  |
| 9 Flat spring (MP4)        | 22 Knob (MP15)               |
| 10 Self-locking screw (H5) | 23 Locking screw (H9)        |
| 11 Pin (MP5)               | 24 Washer (MP16)             |
| 12 Knob (MP6)              | 25 Ball bearing (MP13)       |
| 13 Ball bearing (MP8)      |                              |

Figure 3-4. Bore sight mount, exploded view.

## APPENDIX A REFERENCES

---

The following publications contain information applicable to the organizational and DS maintenance of the AN/PVS-3 and AN/PVS-3A:

DA Pam 310-4

Index of Technical Manuals, Technical Bulletins, Supply Manuals (types 7,8, and 9), Supply Bulletins, and Lubrication Orders.

DA PAM 310-7

Index of Modification Work Orders.

TB 746-10

Field Instructions for Painting and Preserving Electronics Command Equipment.

TM 11-5855-209-10

Operator's Manual, Night Vision Sight, Miniaturized AN/PVS-3 and AN/PVS-3A.

TM 11-6625-366-15

Operator's, Organizational, DS, GS, and Depot Maintenance Manual: Multimeter TS-352B/U.

TM 38-750

The Army Maintenance Management Systems (TAMMS).

## APPENDIX B

### MAINTENANCE ALLOCATION

---

#### Section I. INTRODUCTION

##### B-1. General

This appendix provides a summary of the maintenance operations covered in the equipment literature for the AN/PVS-3. It authorizes categories of maintenance for specific maintenance functions on repairable items and components and the tools and equipment required to perform each function. This appendix may be used as an aid in planning maintenance operations.

##### B-2. Maintenance Functions

Maintenance functions will be limited to and defined as follows:

- a. INSPECT.* To determine serviceability of an item by comparing its physical, mechanical, and electrical characteristics with established standards.
- b. TEST.* To verify serviceability and to detect incipient electrical or mechanical failure by use of special equipment such as gages, meters, etc. This is accomplished with external test equipment and does not include operation of the equipment and operator type tests using internal meters or indicating devices,
- c. SERVICE.* To clean, to preserve, to charge, and to add fuel, lubricants, cooling agents, and air. If it is desired that elements, such as painting and lubricating, be defined separately, they may be so listed.
- d. ADJUST.* To rectify to the extent necessary to bring into proper operating range.
- e. ALIGN.* To adjust two or more components or assemblies of an electrical or mechanical system so that their functions are properly synchronized. This does not include setting the frequency control knob of radio receivers or transmitters to the desired frequency.
- f. CALIBRATE.* To determine the corrections to be made in the readings of instruments or test equipment used in precise measurement. Consists of the comparison of two instruments, one of which is a certified standard of known accuracy, to detect and adjust any discrepancy in the accuracy of the instrument being compared with the certified standard.
- g. INSTALL.* To set up for use in an operational environment such as an encampment, site, or vehicle.
- h. REPLACE.* To replace unserviceable items with serviceable like items.
- i. REPAIR.* To restore an item to serviceable condition through correction of a specific failure or unserviceable condition. This function includes, but is not limited to welding, grinding, riveting, straightening, and replacement of parts other than by the trial and error replacement of running spare type items such as fuses, lamps, or electron tubes.
- j. OVERHAUL.* Normally, the highest degree of maintenance performed by the Army in order to minimize time work in process is consistent with quality and economy of operation. It consists of that maintenance necessary to restore an item to completely serviceable condition as prescribed by maintenance standards in technical publications for each item of equipment. Overhaul normally does not return an item to like new, zero mileage, or zero hour condition.
- k. REBUILD.* The highest degree of materiel maintenance. It consists of restoring equipment as nearly as possible to new condition in accordance with original manufacturing standards. Rebuild is performed only when required by operational considerations or other paramount factors and then only at the depot maintenance category. Rebuild reduces to zero the hours or miles the equipment, or component there-

of, has been in use.

1. *SYMBOLS.* The uppercase letter placed in the appropriate column indicates the lowest level at which that particular maintenance function is to be performed.

**B-3. Explanation of Format**

a. *Column 1, Group Number.* Column 1 lists group numbers, the purpose of which is to identify components, assemblies, sub-assemblies and modules with the next higher assembly.

b. *Column 2, Fictional Group.* Column 2 lists the noun names of components, assemblies, subassemblies and modules on which maintenance is authorized.

c. *Column 3, Maintenance Functions.* Column 3 lists the maintenance category at which performance of the specific maintenance function is authorized. Authorization to perform a function at any category also includes authorization to perform that function at higher categories. The codes used represent the various maintenance categories as follows:

<i>Code</i>	<i>Maintenance category</i>
C .....	Operator/crew
O .....	Organizational maintenance
F.....	Direct support maintenance
H.....	General support maintenance
D.....	Depot maintenance

d. *Column 4, Tools and Test Equipment.* Column 4 specifies, by code, those tools and test equipment required to perform the designated function. The numbers appearing in this column refer to specific tools and test equipment' which are identified in table 1.

e . *Column 5, Remarks.* Self-explanatory.

**B-4. Explanation of Format of Table 1, Tool and Test Equipment Requirements**

The columns in table 1 are as follows:

a. *Tools and Equipment.* The numbers in this column coincide with the numbers used in the tools and equipment column of the maintenance allocation chart. The numbers indicate the applicable tool for the maintenance function.

b. *Maintenance Category.* The codes in this column indicate the maintenance category normally allocated the facility.

c. *Nomenclature.* This column lists tools, test, and maintenance equipment required to perform the maintenance functions.

d. *Federal Stock Number.* This column lists the Federal stock number of the specific tool or test equipment.

e. *Tool Number.* Not used.

SECTION II. MAINTENANCE ALLOCATION CHART

GROUP NUMBER	COMPONENT ASSEMBLY NOMENCLATURE	MAINTENANCE FUNCTIONS										TOOLS AND EQUIPMENT	REMARKS			
		INSPECT	TEST	SERVICE	ADJUST	ALIGN	CALIBRATE	INSTALL	REPLACE	REPAIR	OVERHAUL			REBUILD		
1	NIGHT VISION SIGHT, MINIATURIZED AN/PVS-3	C	F	C	C					F			D	D	1,2	Depot facilities
1A	HOUSING ASSEMBLY	C							F	F					2	
1B	OBJECTIVE LENS ASSEMBLY	F	D					F	F	D	D				2	
1C	EYEPIECE LENS ASSEMBLY	F	D					F	F	D	D				2	
1D	BATTERY	C						C	O							
1E	IMAGE INTENSIFIER ASSEMBLY	F	D					F	F	D	D				2	
1F	EXTERNAL HARDWARE AND SWITCHES	O	F					F	F						1,2	
1G	EYE SHIELD	O						O	O							
1H	CARRYING CASE OR BAG	C						C	O							
1I	BORESIGHT ASSEMBLY	C		C	C			O	O	F					2	
1J	WEAPON MOUNT ASSEMBLY	C		C				O	O	F					2	



TABLE 1. TOOL AND TEST EQUIPMENT REQUIREMENTS

TOOLS AND EQUIPMENT	MAINTENANCE CATEGORY	NOMENCLATURE	FEDERAL STOCK NUMBER	TOOL NUMBER
1	F,H,D	AN/PVS-3 (continued) MULTIMETER TS-352B/U	6625-242-5023	
2	F,H,D	TOOL KIT ELECTRONIC EQUIPMENT TK-100/G	5180-605-0079	

**APPENDIX C**  
**ORGANIZATIONAL AND DIRECT SUPPORT**  
**MAINTENANCE REPAIR PARTS AND SPECIAL TOOLS**

---

**Section I. INTRODUCTION**

**C-1. Scope**

This appendix lists repair parts required for the performance of organizational and direct support of the AN/PVS-3 and AN/PVS-3A.

**NOTE**

No special tools and test equipment are required.

**C-2. General**

This Repair Parts List is divided into the following sections:

*a. Repair Parts for Organizational Maintenance - Section II.* A list of repair parts authorized for the performance of maintenance at the organizational level.

*b. Repair Parts for Direct Support, General Support, and Depot Maintenance - Section III.* A list of repair parts authorized for the performance of maintenance at direct support.

*c. Index - Federal Stock Number Cross Reference to Figure and Item Number or Reference Designation - Section IV.* A list of Federal stock numbers in ascending numerical sequence, followed by a list of reference numbers in ascending alphanumeric sequence, cross-referenced to the illustration figure number or reference designation.

*d. Index - Reference Designation Cross-Reference to Page Number - Section V.* A list of reference designations cross-referenced to page numbers.

**C-3. Explanation of Columns**

The following provides an explanation of columns in the tabular lists:

*a. Source, Maintenance, and Recoverability Codes (SMR).*

(1) Source code indicates the selection status and source for the listed item. Source codes are:

<i>Explanation</i>	
P	Repair parts which are stocked in or supplied from GSA/DSA or Army supply system and authorized for use at indicated maintenance categories.
P2	Repair parts which are procured and stocked for insurance purposes because the combat or military essentiality of the end item dictates that a minimum quantity be available in the supply system.
P9	Assigned to items which are NSA design controlled: unique repair parts, special tools, test, measuring and diagnostic equipment, which are stocked and supplied by the Army COMSEC logistic system, and which are not subject to the provisions of AR 380-41.
P10	Assigned to items which are NSA design controlled: special tools, test, measuring and diagnostic equipment for COMSEC support, which are accountable under the provisions of AR 380-41, and which are stocked and supplied by the Army COMSEC logistic system.
M	Repair parts which are not procured or stocked, but are to be manufactured in indicated maintenance levels.
A	Assemblies which are not procured or stocked as such, but are made up of two or more units. Such component units carry individual stock numbers and descriptions, are procured and stocked separately and can be assembled to form the required assembly at indicated maintenance categories.
X	Parts and assemblies which are not procured or stocked and the mortality of which normally is below that of the applicable end item or component. The failure of such part or assembly should result in retirement of the end item from the supply system.
X1	Repair parts which are not procured or stocked. The requirement for such items will be filled by use of the next higher assembly or component.
X2	Repair parts which are not stocked. The indicated maintenance category requiring such repair parts will attempt to obtain same through cannibalization. Where such repair parts are not obtainable through cannibalization, requirements will be requisitioned, with accompanying justification, through normal supply channels.
G	Major assemblies that are procured with PEMA funds for initial issue only as exchange assemblies at DSU and GSU level. These assemblies will not be stocked above DS and GS level or returned to depot supply level.

(2) Maintenance code indicates the lowest category of maintenance authorized to install the listed item. The maintenance level codes are:

<i>Code</i>	<i>Explanation</i>
C	Operator/Crew
O	Organizational Maintenance
F	Direct Support Maintenance
H	General Support Maintenance
D	Depot Maintenance

(3) Recoverability code indicates whether un-serviceable items should be returned for recovery or salvage. Items not coded are expendable. Recoverability codes are:

<i>Code</i>	<i>Explanation</i>
R	Repair parts and assemblies that are economically reparable at DSU and GSU activities and normally are furnished by supply on an exchange basis.
S	Repair parts and assemblies which are economically reparable at DSU and GSU activities and which normally are furnished by supply on an exchange basis. When items are determined by GSU to be uneconomically reparable, they will be evacuated to a depot for evaluation and analysis before final disposition.
T	High dollar value recoverable repair parts which are subject to special handling and are issued on an exchange basis. Such repair parts normally are repaired or overhauled at depot maintenance activities.
U	Repair parts specifically selected for salvage by reclamation units because of precious metal content, critical materials, or high dollar value reusable casings or castings.

*b. Federal Stock Number.* Indicates the Federal stock number assigned to the item and will be used for requisitioning purposes.

*c. Description.* Indicates the Federal item name and any additional description of the item required. The index number has been included as part of the description to aid in the location of "same as" items. A part number or other reference number is followed by the applicable five-digit Federal supply code for manufacturers in parentheses.

*d. Unit of Measure (U/M).* A two-character alphabetic abbreviation indicating the amount or quantity of the item upon which the allowances are based, e.g., ft. ea, pr, etc.

*e. Quantity Incorporated in Unit.* Indicates the quantity of the item used in the AN/PVS-3 and AN/PVS-3A. A "V" appearing in this column in lieu of a quantity indicates that a definite quantity cannot be indicated. Subsequent appearances of

the same item in the same assembly are indicated by the letters "REF."

*f. Allowances (15-Day Organizational Maintenance, 30-Day DS Maintenance.)* Items authorized for requisition as required are identified by an asterisk in the allowance column.

*g. Illustrations.*

(1) *Figure number.* Indicates the figure number of the illustration in which the item is shown.

(2) *Item number or reference designation.* Indicates the reference designation or item number used to identify the item in the illustration.

**C-4. Special Information**

Identification of the usable on codes of this publication are:

<i>Code</i>	<i>Used on</i>
1	AN/PVS-3
2	AN/PVS-3A

**C-5. Location of Repair Parts**

*a.* This appendix contains two cross-reference indexes (sec. IV and sec. V) to be used to locate a repair part when either the Federal stock number, reference number (manufacturer's part number) or reference designation is known. The first column in each index is prepared in numerical or alphanumeric sequence in ascending order. Where a Federal stock number is not listed, refer to the reference number (manufacturer's part number) immediately following the Federal stock number.

*b.* When the Federal stock number or reference number is known, follow the procedures given in (1) and (2) below.

(1) Refer to the index of Federal stock numbers (sec. IV) and locate the Federal stock number or reference number. The Federal stock number or reference number is cross-referenced to the applicable figure and item number or reference designation.

(2) When the reference designation is determined, refer to the reference designation index (sec. V). The reference designations are listed in numeric-alpha ascending order and are cross-referenced to the page number on which they appear in the repair parts list (sec. II and III). Refer to the page number noted in the index and locate the reference designation in the repair parts list (col. 7a, Repair Parts for Organizational Maintenance or col. 10b, Repair Parts for Direct Support,

General Support, and Depot Maintenance). If the description column indicates that it is a "SAME AS" item, locate the first appearance of the item by the index number referenced.

c. When the reference designation is known, follow the procedures given in *b* (2) above.

d. When neither the Federal stock number, reference number, nor reference designation is known, identify the part in the illustration and follow directions given in *c* above or scrutinize

column 3 of the repair parts list (sec. II and sec. III).

**C-6. Federal Supply Code for Manufacturers.**

<i>Code</i>	<i>Manufactur</i>
80063 .....	Army Electronics Command
81348 .....	Federal Specifications
81349 .....	Military Specifications
96906 .....	Military Standards

(Next printed page is C-5.)

SECTION II REPAIR PARTS FOR ORGANIZATIONAL MAINTENANCE

(1) SMR CODE	(2) FEDERAL STOCK NUMBER	(3) DESCRIPTION	USABLE ON CODE	(4) UNIT OF MEAS	(5) QTY INC IN UNIT	(6) 15-DAY ORGANIZATIONAL MAINTENANCE ALW				(7) ILLUSTRATIONS	
						(a) 1-5	(b) 6-20	(c) 21-50	(d) 51-100	(a) FIG NO.	(b) ITEM NO. OR REFERENCE DESIGNATION
	5855-832-9341	A001 NIGHT VISION SIGHT, MINIATURIZED AN/PVS-3: (INCLUDES MWO 11-5855-209-30/1) (This item is nonexpendable)	1								
	5855-156-4992	A001A NIGHT VISION SIGHT MINIATURIZED AN/PVS-3A: (This item is nonexpendable)	2								
G-O-S	5855-167-7697	A002 NIGHT VISION SIGHT SUBASSEMBLY MI-8201/PVS-3: (INCLUDES MWO 11-5855-209-30/1) This item is nonexpendable)	1	EA	1					3-3	
G-O-S	5855-156-4993	A002A NIGHT VISION SIGHT SUBASSEMBLY MI-8021A/PVS-3 (This item is nonexpendable)	2	EA	1					3-2	1
P-O	5855-925-0114	A081 EYESHIELD ASSY: SCD614703 (80063)	1,2	EA	1	*	*	*	*	3-2	19
P-O-S	5855-433-2350	A110 MOUNT ASSEMBLY, BORESIGHT: SCD635170-2 (80063)	2	EA	1	*	*	*	*	3-2	25
P-O-S	5855-245-8446	A110A MOUNT ASSEMBLY BORESIGHT: SCD-635170-1 (80063)	1	EA	1	*	*	*	*	3-3	15
P-O	5855-245-8444	A149 CAP, COVER ASSY: SCD635148 (80063)	1,2	EA	1	*	*	*	*	3-2	1
P-O-S	5855-134-6257	A162 RECEIVER MOUNT ASSEMBLY, M-14: SCC635152 (80063)	1,2	EA	1	*	*	*	*	2-1	2
X1-O		A163 MOUNT, RECEIVER: SCD635147 (80063)	1,2	EA	1						2A1
P-O-S	5855-134-6258	A168 RECEIVER, MOUNT ASSEMBLY, M-16: SCC635145 (80063)	1,2	EA	1	*	*	*	*	2-2	3
X1-O		A169 BRACKET, M-16: SCD635149 (80063)	1,2	EA	1						3MP1
P-O	6135-056-7612	A175 BATTERY TRAY ASSEMBLY: MILB18BA1533 (81349)	1,2	EA	3	*	*	*	*	3-2	10
P2-O-S	5855-245-8443	A176 CARRYING CASE: SCD635146 (80063)	1,2	EA	1	*	*	*	*		5
X1-O	5855	A177 BODY: SCD635146-1 (80063)	1,2	EA	1						5HP1
X1-O		A180 CAP RETAINER: SCB635151 (80063)	1,2	EA	1						5HP4
X2-O	5320-582-3305	A181 RIVET: MS20600AD4W3 (96906)	1,2	EA	5						5H1
P-O	6640-597-6745	A218 PAPER, LENS: NMP40TYPE1SIZE4 (81348)	1,2	EA	1	*	*	*	*		MP1
P-O	5120-198-5392	A219 KEY, SOCKET HD SCREW: GGQ275TYPE1CLASS1 (81348)	1,2	EA	1	*	*	*	*		MP2

C-5, Change 3

SECTION III REPAIR PARTS FOR DIRECT SUPPORT, GENERAL SUPPORT, AND DEPOT MAINTENANCE

(1) SMR CODE	(2) FEDERAL STOCK NUMBER	(3) DESCRIPTION  REFERENCE NUMBER & MFR. CODE	USABLE ON CODE	(4) UNIT OF MEAS	(5) QTY INC IN UNIT	(6) 30-DAY DS MAINT ALLOWANCE			(7) 30-DAY GS MAINT ALLOWANCE			(8) 1 YR ALW PER EQUIP (WTQCY)	(9) DEPOT MAINT ALW PER 100 EQUIP	(10) ILLUSTRATIONS		
						(a) 1-20	(b) 21-50	(c) 51-100	(a) 1-20	(b) 21-50	(c) 51-100			(a) FIG NO.	(b) ITEM NO. OR REFERENCE DESIGNATION	
	5855-832-9341	A001 NIGHT VISION SIGHT, MINIA- TURIZED AN/PVS-3: (INCLUDES MWO 11-5855-209-30/1) (This item is nonexpendable)	1											1		
	5855-156-4992	A001A NIGHT VISION SIGHT MINIA- TURIZED AN/PVS-3A: (This item is nonexpendable)	2											1		
G-O-S	5855-167-7697	A002 NIGHT VISION SIGHT SUBAS- SEMBLY MM8201/PVS-3: (INCLUDES MWO 11-5855-209-30/1) This item is nonexpendable)	1	EA	1									3-3		
G-O-S	5855-156-4993	A002A NIGHT VISION SIGHT SUBAS- SEMBLY MX-8201A/PVS-3 (This item is nonexpendable)	2	EA	1									3-2	1	
P-F-T	5855-054-8540	A003 OBJECTIVE LENS ASSEMBLY: SCD635077-1 (80063)	1,2	EA	1	*	*	*						3-2	2	
P-F-S	5855-433-2348	A033 BODY ASSEMBLY: SCD635053-2 (80063)	2	EA	1	*	*	*						3-2	4	
P-F-S		A033A BODY ASSEMBLY: SC-D-635053-1 (80063)	1	EA	1	*	*	*						3-3	1	
P-F	6135-491-5252	A041 COVER ASSEMBLY: SCC635075-1 (80063)	1,2	EA	1	*	*	*						3-2	9	
P-F	5305-880-6896	A042 SCREW, KNURLED: SCB635082 (80063)	1,2	EA	1	*	*	*						3-2	1A2A1H1	
P-F	5305-880-6895	A043 SCREW, SHOULDER: SCB635064 (80063)	1,2	EA	1	*	*	*						3-2	1A2A1H2	
P-F	5310-880-9367	A044 NUT, KNURLED: SCB635065 (80063)	1,2	EA	1	*	*	*						3-2	1A2A1H3	
P-F	5315-880-8975	A045 PIN, SLOTTED: SCB635066 (80063)	1,2	EA	1	*	*	*						3-2	7	
P-F	5930-937-2137	A056 SWITCH, TOGGLE: SCC607138 (80063)	1,2	EA	1	*	*	*						3-2	11	
P-F	8030-081-2325	A057 SFALING, LKQ, AND KING CMPD: MIL522473GRADEB (81349)	1,2	CM	V	*	*	*							1A2AMP1	
P-F	5855-433-2349	A060 TUBE FOCUSING ASSEMBLY: SCD635054-2 (80063)	2	EA	1	*	*	*						3-2	13	
P-F	5855-054-8503	A060A TUBE ASSEMBLY: SC-D-635054-1 (80063)	1	EA	1	*	*	*						3-3	3	
P-F	5855-167-7706	A062 SPACER, IMAGE INTENSIFIER TUBE: SCB635067 (80063)	1,2	EA	1	*	*	*						3-2	1A2AMP3	
P-F	5855-167-7699	A068 COUPLER, RING: SCD635069 (80063)	1,2	EA	1	*	*	*						3-2	16	
P-F	5330-802-1360	A069 PACING, PREFMD: SCB635059-5 (80063)	1,2	EA	1	*	*	*						3-2	12	
P-F	5855-133-8772	A070 SCREW, GUIDE: SCB635119 (80063)	1,2	EA	1	*	*	*						3-2	8	
P-F	5305-239-7858	A071 SETSCREW: SCB635087-1 (80063)	1,2	EA	4	*	*	*						3-2	1A2H2	
P-F	5305-239-7858	A072 SETSCREW: SAME AS A071	1,2	EA	REF	*	*	*							1A2H3	
P-F	5305-239-7858	A073 SETSCREW: SAME AS A071	1,2	EA	REF	*	*	*							1A2H4	
P-F	5305-239-7858	A074 SETSCREW: SAME AS A071	1,2	EA	REF	*	*	*							1A2H5	
P-F	5305-812-5788	A075 SETSCREW: SCB635087-3 (80063)	1,2	EA	4	*	*	*						3-2	24	

C-6, Change 3

SECTION III REPAIR PARTS FOR DIRECT SUPPORT, GENERAL SUPPORT, AND DEPOT MAINTENANCE (continued)

(1) SNR CODE	(2) FEDERAL STOCK NUMBER	(3) DESCRIPTION  REFERENCE NUMBER & MFR. CODE	(4) USABLE ON CODE	(5) UNIT OF MEAS  QTY INC IN UNIT	(6) 30-DAY DS MAINT ALLOWANCE			(7) 30-DAY GS MAINT ALLOWANCE			(8) 1 YR ALW PER EQUIP CNTGCT	(9) DEPOT MAINT ALW PER 100 EQUIP	(10) ILLUSTRATIONS	
					(a) 1-20	(b) 21-50	(c) 51-100	(a) 1-20	(b) 21-50	(c) 51-100			(a) FIG NO.	(b) ITEM NO. OR REFERENCE DESIGNATION
					P-F	5305-812-5788	A076 SETSCREW: SAME AS A075	1,2	EA	REF			*	*
P-F	5305-812-5788	A077 SETSCREW: SAME AS A075	1,2	EA	REF	*	*	*						1A2H8
P-F	5305-812-5788	A078 SETSCREW: SAME AS A075	1,2	EA	REF	*	*	*						1A2H9
P-F	6850-295-7685	A079 SILICONE CMPD: MILS8660 (80063)	1,2	CN	V	*	*	*						1A2HP3
P-F-S	5855-409-0920	A080 EYEPiece ASSY: SCD635079-2 (80063)	1,2	EA	1	*	*	*					3-2	18
P-O	5855-925-0114	A081 EYESHIELD ASSY: SCD614703 (80063)	1,2	EA	1	*	*	*					3-2	19
P-F	5855-245-8445	A102 ADAPTER PLATE,EYEPiece CELL: SCD635167 (80063)	1,2	EA	1	*	*	*					3-2	20
P-F	5305-960-7458	A103 SCREW,MODIFIED: SCB635130 (80063)	1,2	EA	4	*	*	*					3-2	21
P-F	5855-245-8442	A107 SPACER,EYEPiece: SCC635174 (80063)	1,2	EA	1	*	*	*					3-2	26
P-O-S	5855-433-2350	A110 MOUNT ASSEMBLY,BORESIGHT: SCD635170-2 (80063)	2	EA	1	*	*	*					3-2	25
P-O-S	5855-245-8446	A110A MOUNT ASSEMBLY,BORESIGHT: SC-D-635170-1 (80063)	1	EA	1	*	*	*					3-3	15
P-F	5855-409-8150	A111 FRAME,BRSIT MOUNT ASSY: SCD635168 (80063)	1,2	EA	1	*	*	*					3-4	5
X1-F		A112 FRAME: SCD635168-2 (80063)	1,2	EA	1									1A4A1MP1
P-F	5305-087-3087	A118 SCREW,LOCKING: SCB614662 (80063)	1,2	EA	2	*	*	*					3-4	23
P-F	5305-087-3087	A119 SCREW,LOCKING: SAME AS A118	1,2	EA	REF	*	*	*						1A4H2
P-F	5355-087-2770	A120 KNOB,LOCKING: SCC614661 (80063)	1,2	EA	2	*	*	*					3-4	22
P-F	5355-087-2770	A121 KNOB,LOCKING: SAME AS A120	1,2	EA	REF	*	*	*						1A4H4
P-F	5315-434-5759	A122 PIN,GROVED HEADLESS: SCB635155 (80063)	1,2	EA	1	*	*	*					3-4	21
P-F	5360-433-2415	A123 SPRING,SPIRAL,TORSION: SCB635172 (80063)	1,2	EA	1	*	*	*					3-4	6
P-F	5305-448-4673	A124 SCREW,CAPTIVE BORESIGHT MOUNT: SCB635157-1 (80063)	1,2	EA	1	*	*	*					3-4	7
P-F	5305-448-4674	A125 SCREW,CAPTIVE BORESIGHT MOUNT: SCB635157-2 (80063)	2	EA	1	*	*	*					3-4	8
P-F	5855-409-8151	A126 PIN,BORESIGHT MOUNT: SCB635165 (80063)	1,2	EA	1	*	*	*					3-4	11
P-F	5855-409-8149	A127 SHAFT,BRSIT MT: SCB635158 (80063)	1,2	EA	1	*	*	*					3-4	1A4MP2
P-F	5310-087-3057	A128 WASHER: SCB614660 (80063)	1,2	EA	2	*	*	*					3-4	24
P-F	5310-087-3057	A129 WASHER: SAME AS A128	1,2	EA	REF	*	*	*						1A4H10
P-F	5355-409-8116	A130 KNOB,BORESIGHT MOUNT: SCC635177 (80063)	1,2	EA	2	*	*	*					3-4	12
P-F	5355-409-8116	A131 KNOB,BORESIGHT MOUNT: SAME AS A130	1,2	EA	REF	*	*	*						1A4H12
P-F	5855-409-8148	A132 SCREW,BRSIT MT: SCB635159 (80063)	1,2	EA	1	*	*	*					3-4	1A4H13
P-F	5855-409-8152	A133 POST,BORESIGHT MOUNT: SCB635160 (80063)	1,2	EA	1	*	*	*					3-4	19

C-7, Change 3

SECTION III REPAIR PARTS FOR DIRECT SUPPORT, GENERAL SUPPORT, AND DEPOT MAINTENANCE (continued)  
SECTION III REPAIR PARTS FOR DIRECT SUPPORT, GENERAL SUPPORT, AND DEPOT MAINTENANCE (CONTINUED)

(1) SMR CODE	(2) FEDERAL STOCK NUMBER	(3) DESCRIPTION  REFERENCE NUMBER & MFR. CODE	USABLE ON CODE	(4) UNIT OF MEAS	(5) QTY INC IN UNIT	(6) 30-DAY DS MAINT ALLOWANCE			(7) 30-DAY GS MAINT ALLOWANCE			(8) 1 YR ALW PER EQUIP CNTGCTY	(9) DEPOT MAINT ALW PER 100 EQUIP	(10) ILLUSTRATIONS	
						(a) 1-20	(b) 21-50	(c) 51-100	(a) 1-20	(b) 21-50	(c) 51-100			(a) FIG NO.	(b) ITEM NO. OR REFERENCE DESIGNATION
P-F	5360-433-2416	A134 SPRING, HELICAL CPRSN: SCB635166 (80063)	1,2	EA	2	*	*	*					3-4	20	
P-F	5360-433-2416	A135 SPRING, HELICAL CPRSN: SAME AS A134	1,2	EA	REF	*	*	*						1A4MP5	
P-F	5310-420-0610	A136 WASHER, THRUST, BORESIGHT MOUNT: SCB635161 (80063)	1,2	EA	1	*	*	*					3-4	17	
P-F	5365-419-4627	A137 RING, RTNG: SCB635162-18 (80063)	1,2	EA	1	*	*	*					3-4	16	
P-F	5365-415-9272	A138 RING, RTNG: SCB635162-25 (80063)	1,2	EA	1	*	*	*					3-4	3	
P-F	5315-844-5644	A139 PIN-SPRING: MS171436 (96906)	1,2	EA	2	*	*	*					3-4	21	
P-F	5315-844-5644	A140 PIN-SPRING: SAME AS A139	1,2	EA	REF	*	*	*						1A4H16	
P-F	5315-807-7957	A141 PIN-SPRING: MS16555-608 (96906)	1,2	EA	1	*	*	*					3-4	2	
P-F	3110-294-2614	A142 BEARING, BALL: MS9461-05 (96906)	1,2	EA	1	*	*	*					3-4	14	
P-F	3110-131-7071	A143 BEARING, BALL: MS9461-03 (96906)	1,2	EA	2	*	*	*					3-4	25	
P-F	3110-131-7071	A144 BEARING, BALL: SAME AS A143	1,2	EA	REF	*	*	*						1A4MP10	
P-F	5305	A145 SCREW, SELF-LOCKING, TRUSS HD: SCB635163 (80063)	1,2	EA	1	*	*	*					3-4	10	
P-F	9150-754-2595	A146 GREASE, MOLYBDENUM DISULFIDE: MILG21164 (81349)	1,2	CM	V	*	*	*						1A4MP11	
P-F	5855-433-2351	A147 CROSSBAR, BRSIT MOUNT: SCD635164-2 (80063)	2	EA	1	*	*	*					3-4	4	
P-F		A147A CROSSBAR, BORESIGHT MOUNT: SC-D-635164-1 (80063)	1	EA	1	*	*	*					3-3		
P-F	5360-415-2229	A148 SPRING, FLAT: SCB635154 (80063)	2	EA	1	*	*	*					3-4	9	
X-F		A148A STRAP, BORESIGHT MOUNT: SG-G-635154 (80063)	1	EA	1								3-3	12	
X-F		A148B SCREW, CAPTIVE, BORESIGHT MOUNT: SG-B-635156 (80063)	1	EA	1								3-3	13	
X-F		A148C SPRING, FLAT: SG-G-635175 (80063)	1	EA	1								3-3	14	
X-F		A148D ADAPTER, BORESIGHT MOUNT: SG-G-635169 (80063)	1	EA	1								3-3	10	
P-O	5855-245-8444	A149 CAP, COVER ASST: SCD635148 (80063)	1,2	EA	1	*	*	*					3-2	1	
P-F	5330-935-9238	A152 PACKING, PREFMD: SCB635059-1 (80063)	1,2	EA	1	*	*	*					3-2	17	
P-F	5330-935-9239	A153 PACKING, PREFMD: SCB635059-3 (80063)	1,2	EA	1	*	*	*					3-2	3	
P-F	5305-682-8046	A154 SCREW, MODIFIED SOCKET HEAD: SCB635133-7 (80063)	1,2	EA	4	*	*	*					3-2	5	
P-F	5305-682-8046	A155 SCREW, MODIFIED SOCKET HEAD: SAME AS A154	1,2	EA	REF	*	*	*						1MP4	
P-F	5305-682-8046	A156 SCREW, MODIFIED SOCKET HEAD: SAME AS A154	1,2	EA	REF	*	*	*						1MP5	
P-F	5305-682-8046	A157 SCREW, MODIFIED SOCKET HEAD: SAME AS A154	1,2	EA	REF	*	*	*						1MP6	
P-F		A158 SCREW, MODIFIED SOCKET HEAD: SCB635133-33 (80063)	1,2	EA	2	*	*	*					3-3	11	
P-F		A159 SCREW, MODIFIED SOCKET HEAD: SAME AS A158	1,2	EA	REF	*	*	*						1MP8	

G-8, Change 3



SECTION III REPAIR PARTS FOR DIRECT SUPPORT, GENERAL SUPPORT, AND DEPOT MAINTENANCE (continued)

(1) SMR CODE	(2) FEDERAL STOCK NUMBER	(3) DESCRIPTION  REFERENCE NUMBER & MFR. CODE	USABLE ON CODE	(4) UNIT OF MEAS	(5) QTY INC IN UNIT	(6) 30-DAY DS MAINT ALLOWANCE			(7) 30-DAY GS MAINT ALLOWANCE			(8) 1 YR ALW PER EQUIP CATGCT	(9) DEPOT MAINT ALW PER 100 EQUIP	(10) ILLUSTRATIONS	
						(a) 1-20	(b) 21-50	(c) 51-100	(a) 1-20	(b) 21-50	(c) 51-100			(a) FIG NO.	(b) ITEM NO. OR REFERENCE DESIGNATION
						P-F	6850-295-7685	A161 SILICONE CMPD: SAME AS A079	1,2	CN	V			*	*
P-O-S	5855-134-6257	A162 RECEIVER MOUNT ASSEMBLY,M-14 SCC635152 (80063)	1,2	EA	1	*	*	*						2-1	2
X1-O		A163 MOUNT, RECEIVER: SCD635147 (80063)	1,2	EA	1										2A1
X1-F		A164 MOUNT RECEIVER: SCD635147-2 (80063)	1,2	EA	1										2A1MP1
X1-F		A165 PIN, STR, HDLS: SCD635147-3 (80063)	1,2	EA	1										2A1MP2
P-F	5310-087-3055	A166 WASHER, LOCK: SCB645752-158 (80063)	1,2	EA	1	*	*	*							2MP1
P-F	5305	A167 SCREW, CAP, SOC HD: SCC607134 (80063)	1,2	EA	1	*	*	*							2H1
P-O-S	5855-134-6258	A168 RECEIVER MOUNT ASSEMBLY,M-16: SCC635145 (80063)	1,2	EA	1	*	*	*						2-2	3
X1-O		A169 BRACKET, M-16 SCD635149 (80063)	1,2	EA	1										3MP1
P-F	5855-087-1565	A170 TAB: SCC607232 (80063)	1,2	EA	1	*	*	*							3MP2
P-F	5310-087-3055	A171 WASHER, LOCK: SAME AS A166	1,2	EA	1	*	*	*							3MP3
P-F	5310-087-3099	A172 NUT, WING, PL: SCB607255 (80063)	1,2	EA	1	*	*	*							1A3MP4
P-F	5305-087-3080	A173 SCREW, HEX HD MACHINE: SCB645759-312 (80063)	1,2	EA	1	*	*	*							3H1
P-F	5310	A174 WASHER, FLAT: SCB645751-809 (80063)	1,2	EA	1	*	*	*							3MP5
P-O	6135-056-7612	A175 BATTERY TRAY ASSEMBLY: MILB18BA1533 (81349)	1,2	EA	3	*	*	*						3-2	10
P2-O-S	5855-245-8443	A176 CARRYING CASE: SCD635146 (80063)	1,2	EA	1	*	*	*							5
X1-O	5855	A177 BODY: SCD635146-1 (80063)	1,2	EA	1										5MP1
X1-F		A178 CAP: SCD635146-2 (80063)	1,2	EA	1										5MP2
P-F	5330-437-7314	A179 SEAL: SCC635176 (80063)	1,2	EA	1	*	*	*							5MP3
X1-O		A180 CAP RETAINER: SCB635151 (80063)	1,2	EA	1										5MP4
X2-O	5320-582-3305	A181 RIVET: MS20600AD4W3 (96906)	1,2	EA	5										5H1
X1-F		A182 CUSHION, TOP: SCD635153-1 (80063)	1,2	EA	1										5MP5
X1-F		A183 CUSHION, BOTTOM: SCD635153-2 (80063)	1,2	EA	1										5MP6
X1-F		A184 BUCKLE: MTLB543TYPE3STYLE3CLASS3 (81349)	1,2	EA	1										5MP7
X2-F	5340-078-7029	A185 CLIP, END, STRAP: MILC496 (81349)	1,2	EA	1										5MP12
X-F		A186 KEEPER, WITH SLIDE: MILH9890TYPEK (81349)	2	EA	2										5MP8
X-F		A187 KEEPER, WITH SLIDE: SAME AS A186	2	EA	REF										5MP9
X-F		A188 WEBBING AND TAPE, TEXTILE: MILW530TYPE2A (81349)	2	EA	1										5MP10

C-9, Change 3

SECTION III REPAIR PARTS FOR DIRECT SUPPORT, GENERAL SUPPORT, AND DEPOT MAINTENANCE (continued)

(1) SIR CODE	(2) FEDERAL STOCK NUMBER	(3) DESCRIPTION  REFERENCE NUMBER & MFR. CODE	USABLE ON CODE	(4) UNIT OF MEAS	(5) QTY INC IN UNIT	(6) 30-DAY DS MAINT ALLOWANCE			(7) 30-DAY GS MAINT ALLOWANCE			(8) 1 YR ALW PER EQUIP CNTGCT	(9) DEPOT MAINT ALW PER 100 EQUIP	(10) ILLUSTRATIONS	
						(a)	(b)	(c)	(a)	(b)	(c)			(a) FIG NO.	(b) ITEM NO. OR REFERENCE DESIGNATION
						1-20	21-50	51-100	1-20	21-50	51-100				
X-F		A189 WEBBING AND TAPE, TEXTILE: MILA530TYPE (81349)	2	EA	1										5MP11
X2-F	5320-582-3268	A190 RIVET: MS2060QAD6W3 (96906)	2	EA	3										5MP12
P-F		A191 ADHESIVE: MILA25457 (81349)	2	CN	1	*	*	*							5MP13
P-F-T	5855-054-8490	A192 IMAGE, INTENSIFIER ASSY, 18MM; SCD646776 (80063)	1,2	EA	1	*	*	*					3-2		14
P-F	5340-880-7831	A193 CAP, PROTECTIVE: SCB611742 (80063)	2	EA	2	*	*	*							6MP1
P-F	5340-880-7831	A194 CAP, PROTECTIVE: SAME AS A193	2	EA	REF	*	*	*							6MP2
X-F		A197 CUSHION, SHIPPING AND STORAGE: SCD646761 (80063)	2	EA	2										6MP5
X-F		A198 CUSHION, SHIPPING AND STORAGE: SAME AS A197	2	EA	REF										6MP6
P-O	6640-597-6745	A218 PAPER, LENS: MMMP40TTPA1815EA (81348)	1,2	EA	1	*	*	*							MP1
P-O	5120-198-5392	A219 KEY, SOCKET HD SCREEN: GGGR275TTPK1CLASS1 (81348)	1,2	EA	1	*	*	*							MP2
P-F	5310-935-9097	A220 WASHER, SPRING TENSION: SCC635129 (80063)	1,2	EA	1	*	*	*					3-2		15

C-10, Change 3

**SECTION IV INDEX-FEDERAL STOCK NUMBER CROSS REFERENCE  
TO FIGURE AND ITEM NUMBER OR REFERENCE DESIGNATION**

FEDERAL STOCK NUMBER	FIGURE NUMBER	ITEM NUMBER OR REF. DESIGNATION	FEDERAL STOCK NUMBER	FIGURE NUMBER	ITEM NUMBER OR REF. DESIGNATION
3110-131-7071		LA4MP10	5855-245-8445	3-2	20
3110-131-7071	3-4	25	5855-245-0446	3-3	15
3110-294-2614	3-4	14	5855-409-0920	3-2	18
5120-198-5392		MP2	5855-409-8148	3-4	1A4H13
5305-087-3080		3H1	5855-409-8149	3-4	1A4MP2
5305-087-3087		1A4H2	5855-409-8150	3-4	5
5305-087-3087	3-4	23	5855-409-8151	3-4	11
5305-239-7858	3-2	1A2H2	5855-409-8152	3-4	19
5305-239-7858		3A2H3	5855-433-2348	3-2	4
5305-239-7858		1A2H4	5855-633-2349	3-2	13
5305-239-7858		1A2H5	5855-433-2350	3-2	25
5305-448-4673	3-4	7	5855-433-2351	3-4	4
5305-448-4674	3-4	8	5855-925-0114	3-2	19
5305-682-8046		1MP4	5930-937-2137	3-2	11
5305-682-8046		1MP5	6135-491-5252	3-2	9
5305-682-8046		1MP6	6135-056-7612	3-2	10
5305-682-8046	3-2	5	6640-597-6745		MP1
5305-812-5788		1A2H7	6850-295-7685		1MP10
5305-812-5788		3A2H8	6850-295-7685		1A2MP3
5305-812-5788		1A2H9	8030-081-2325		1A2A1MP1
5305-812-5788	3-2	24	9150-754-2595		1A4MP11
5305-880-6895	3-2	3A2A1H2			
5305-880-6896	3-2	3A2A1H1			
5305-960-7458	3-2	21			
5310-087-3055		2MP1			
5310-087-3055		3MP3			
5310-087-3057		1A4H10			
5310-087-3057	3-4	24	MILA25457	81349	5MP13
5310-087-3099		1A3MP4	MILB543TYPE3STYLE	81349	5MP7
5310-420-0610	3-4	17	3CLASS3		
5310-880-9367	3-2	1A2A1H3	MILH9890TYPEX	81349	5MP8
5310-935-9097	3-2	15	MILH9890TYPEX	81349	5MP9
5315-434-5759	3-4	21	MILW530TYPE	81349	5MP11
5315-807-7957	3-4	2	MILW530TYPE2A	81349	5MP10
5315-844-5644		1A4H16	SCB635133-33	80063	1MP8
5315-844-5644	3-4	21	SCB635133-33	80063	11
5315-880-8975	3-2	7	SCB635151	80063	5MP4
5320-582-3268		5MP12			
5320-582-3305		5H1	SCB635163	80063	3-4 10
5330-437-7314		5MP3	SCB645751-809	80063	3MP5
5330-802-1360	3-2	12	SCC607134	80063	2H1
5330-935-9238	3-2	17	SC-C-635144	80063	3-3 12
5330-935-9239	3-2	3	SC-B-635156	80063	3-3 13
5340-078-7029		5MP12	SC-C-635169	80063	3-3 10
5340-880-7831		6MP1	SC-C-635175	80063	3-3 14
5340-880-7831		6MP2	SC-D-635053-1	80063	3-3 1
5355-087-2770		1A4H4	SCD635146-1	80063	5MP1
5355-087-2770	3-4	22	SCD635146-2	80063	5MP2
5355-409-8116		1A4H12	SCD635147	80063	2A1
5355-409-8116	3-4	12	SCD635147-2	80063	2A1MP1
5360-415-2229	3-4	9	SCD635147-3	80063	2A1MP2
5360-433-2415	3-4	6	SCD635149	80063	3MP1
5360-433-2416		1A4MP5	SCD635153-1	80063	5MP5
5360-433-2416	3-4	20	SCD635153-2	80063	5MP6
5365-415-9272	3-4	3	SCD635168-2	80063	1A4A1MP1
5365-419-4627	3-4	16	SCD646781	80063	6MP5
5855-054-8490	3-2	14	SCD646781	80063	6MP6
5855-054-8503	3-3	3			
5855-054-8540	3-2	2			
5855-087-1565		3MP2			
5855-133-8772	3-2	8			
5855-134-6257	2-1	2			
5855-134-6258	2-2	3			
5855-156-4993	3-2	1			
5855-167-7699	3-2	16			
5855-167-7706	3-2	1A2A2MP3			
5855-245-8442	3-2	26			
5855-245-8443		5			
5855-245-8444	3-2	1			

**SECTION V INDEX - REFERENCE DESIGNATION  
CROSS REFERENCE TO PAGE NUMBER**

REFERENCE DESIGNATION	PAGE NUMBER	REFERENCE DESIGNATION	PAGE NUMBER	REFERENCE DESIGNATION	PAGE NUMBER
1	C-5, C-6				
IMP4	C-8				
IMP5	C-8				
IMP6	C-8				
IMP8	C-8				
IMP10	C-9				
1A2A1H1	C-6				
1A2A1H2	C-6				
1A2A1H3	C-6				
1A2A1MP1	C-6				
1A2H2	C-6				
1A2H3	C-6				
1A2H4	C-6				
1A2H5	C-6				
1A2H7	C-7				
1A2H8	C-7				
1A2H9	C-7				
1A2MP3	C-7				
1A2A2MP3	C-6				
1A3MP4	C-9				
1A4H2	C-7				
1A4H4	C-7				
1A4H10	C-7				
1A4H12	C-7				
1A4H13	C-7				
1A4H16	C-8				
1A4A1MP1	C-7				
1A4MP2	C-7				
1A4MP5	C-8				
1A4MP10	C-8				
1A4MP1	C-8				
2	C-5, C-9				
2H1	C-9				
2MP1	C-9				
2A1	C-5, C-9				
2A1MP2	C-9				
2A1MP2	C-9				
3	C-5, C-9				
3H1	C-9				
3MP1	C-5, C-9				
3MP2	C-9				
3MP3	C-9				
3MP5	C-9				
5	C-5, C-9				
5H1	C-5, C-9				
5MP1	C-9				
5MP2	C-9				
5MP3	C-9				
5MP4	C-5, C-9				
5MP5	C-9				
5MP6	C-9				
5MP7	C-9				
5MP8	C-9				
5MP9	C-9				
5MP10	C-9				
5MP11	C-10				
5MP12	C-10				
5MP13	C-10				
6MP1	C-10				
6MP2	C-10				
6MP5	C-10				
6MP6	C-10				
MP1	C-5, C-10				
MP2	C-5, C-10				

C-12, Change 3

By Order of the Secretary of the Army:

Official:

KENNETH G. WICKHAM,  
*Major General, United States Army,  
The Adjutant General.*

HAROLD K. JOHNSON,  
*General, United States Army,  
Chief of Staff.*

RECOMMENDED CHANGES TO EQUIPMENT TECHNICAL PUBLICATIONS



THEN...JOT DOWN THE  
DOPE ABOUT IT ON THIS FORM.  
CAREFULLY TEAR IT OUT, FOLD IT  
AND DROP IT IN THE MAIL.

SOMETHING WRONG WITH PUBLICATION

FROM: (PRINT YOUR UNIT'S COMPLETE ADDRESS)

DATE SENT

PUBLICATION NUMBER

PUBLICATION DATE

PUBLICATION TITLE

BE EXACT PIN-POINT WHERE IT IS

PAGE  
NO.

PARA-  
GRAPH

FIGURE  
NO.

TABLE  
NO.

IN THIS SPACE, TELL WHAT IS WRONG  
AND WHAT SHOULD BE DONE ABOUT IT.

TEAR ALONG PERFORATED LINE

PRINTED NAME, GRADE OR TITLE AND TELEPHONE NUMBER

SIGN HERE

# THE METRIC SYSTEM AND EQUIVALENTS

## WEIGHT MEASURE

1 Centimeter = 10 Millimeters = 0.01 Meters = 0.3937 Inches  
 1 Meter = 100 Centimeters = 1000 Millimeters = 39.37 Inches  
 1 Kilometer = 1000 Meters = 0.621 Miles

## WEIGHTS

1 Gram = 0.001 Kilograms = 1000 Milligrams = 0.035 Ounces  
 1 Kilogram = 1000 Grams = 2.2 lb.  
 1 Metric Ton = 1000 Kilograms = 1 Megagram = 1.1 Short Tons

## LIQUID MEASURE

1 Milliliter = 0.001 Liters = 0.0338 Fluid Ounces  
 1 Liter = 1000 Milliliters = 33.82 Fluid Ounces

## SQUARE MEASURE

1 Sq. Centimeter = 100 Sq. Millimeters = 0.155 Sq. Inches  
 1 Sq. Meter = 10,000 Sq. Centimeters = 10.76 Sq. Feet  
 1 Sq. Kilometer = 1,000,000 Sq. Meters = 0.386 Sq. Miles

## CUBIC MEASURE

1 Cu. Centimeter = 1000 Cu. Millimeters = 0.06 Cu. Inches  
 1 Cu. Meter = 1,000,000 Cu. Centimeters = 35.31 Cu. Feet

## TEMPERATURE

$5/9(^{\circ}\text{F} - 32) = ^{\circ}\text{C}$   
 212° Fahrenheit is equivalent to 100° Celsius  
 90° Fahrenheit is equivalent to 32.2° Celsius  
 32° Fahrenheit is equivalent to 0° Celsius  
 $9/5^{\circ}\text{C} + 32 = ^{\circ}\text{F}$

## APPROXIMATE CONVERSION FACTORS

TO CHANGE	TO	MULTIPLY BY
Inches	Centimeters	2.540
Feet	Meters	0.305
Yards	Meters	0.914
Miles	Kilometers	1.609
Square Inches	Square Centimeters	6.451
Square Feet	Square Meters	0.093
Square Yards	Square Meters	0.836
Square Miles	Square Kilometers	2.590
Acres	Square Hectometers	0.405
Cubic Feet	Cubic Meters	0.028
Cubic Yards	Cubic Meters	0.765
Fluid Ounces	Milliliters	29.573
its	Liters	0.473
arts	Liters	0.946
allons	Liters	3.785
Ounces	Grams	28.349
Pounds	Kilograms	0.454
Short Tons	Metric Tons	0.907
Pound-Feet	Newton-Meters	1.356
Pounds per Square Inch	Kilopascals	6.895
Miles per Gallon	Kilometers per Liter	0.425
Miles per Hour	Kilometers per Hour	1.609

TO CHANGE	TO	MULTIPLY BY
Centimeters	Inches	0.394
Meters	Feet	3.280
Meters	Yards	1.094
Kilometers	Miles	0.621
Square Centimeters	Square Inches	0.155
Square Meters	Square Feet	10.764
Square Meters	Square Yards	1.196
Square Kilometers	Square Miles	0.386
Square Hectometers	Acres	2.471
Cubic Meters	Cubic Feet	35.315
Cubic Meters	Cubic Yards	1.308
Milliliters	Fluid Ounces	0.034
Liters	Pints	2.113
Liters	Quarts	1.057
ers	Gallons	0.264
ms	Ounces	0.035
ograms	Pounds	2.205
Metric Tons	Short Tons	1.102
Newton-Meters	Pounds-Feet	0.738
Kilopascals	Pounds per Square Inch	0.145
ometers per Liter	Miles per Gallon	2.354
ometers per Hour	Miles per Hour	0.621

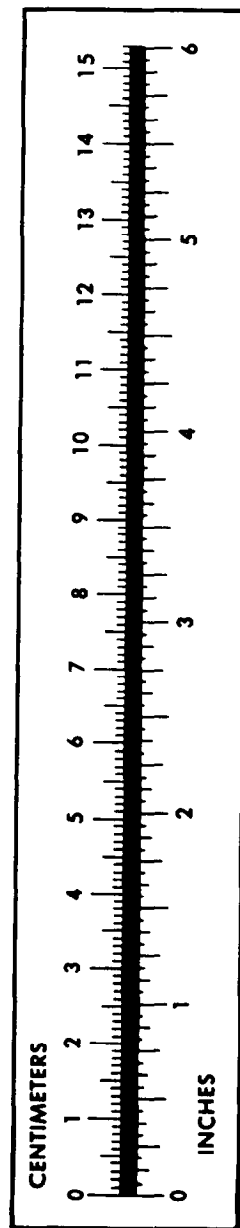

**PIN: 018621-005**